

6' or 8' Bench Frame – Portable

Tools required: drill (not included). One to two person assembly recommended.

PARTS

Fully Assembled



Board A x 4
(Predrilled holes centered)

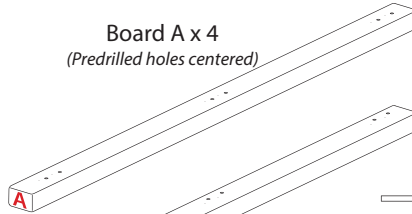

Board B x 3
(Predrilled holes off-centered)

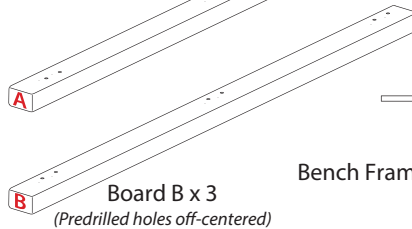

Bench Frame x 3

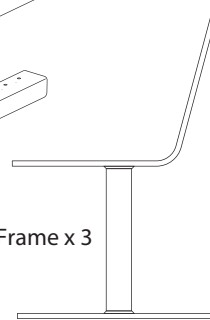

T27 Torx Bit x 1

2.25" Cap Screw x 42

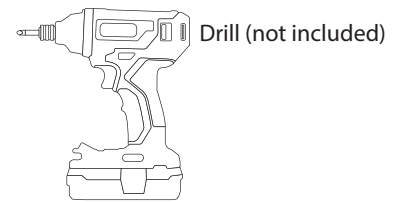

ASSEMBLY

STEP 1

Using drill & Torx bit to fasten cap screws:

1. Lay side-by-side four boards in this order, holes facing up – B, A, A, A.
2. Attach one bench frame using eight 2.25" cap screws. Rotate B board 180° if necessary so that predrilled holes line up.
3. Repeat #2 using bench frames and 2.25" cap screws.
4. Set upright.

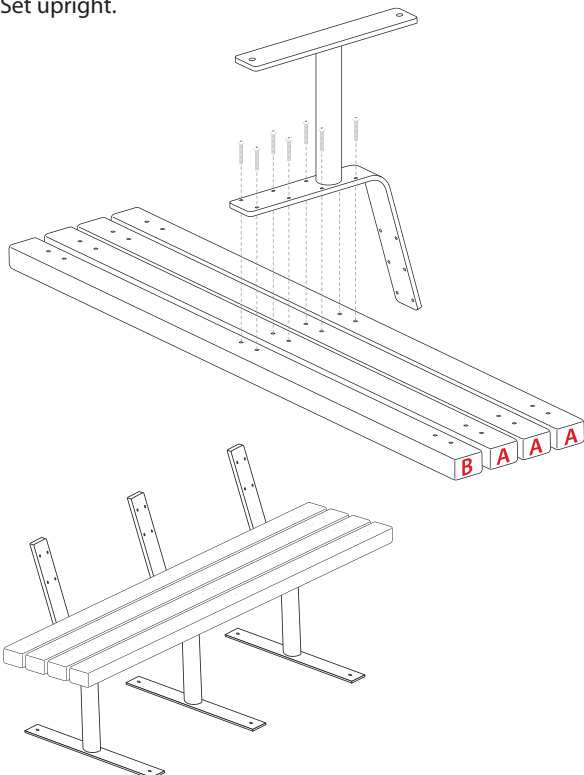

STEP 2

Using drill & Torx bit to fasten cap screws:

1. Attach one A board to bench frame using six 2.25" cap screws.
2. Attach B boards using six 2.25" cap screws. Rotate 180° if necessary so that pre-drilled holes line up.
3. Set upright.

