

Single Sided Gun Rack

Tools required: 5/32" allen wrench (included), drill (not included). One to two person assembly recommended.

PARTS

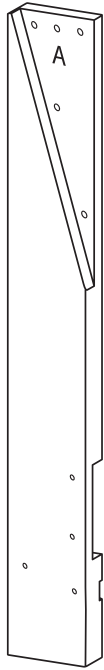

Leg A
Rear

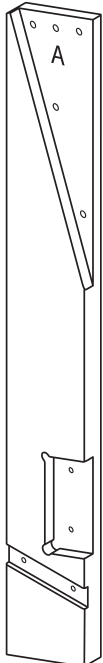

Leg A
Front



Leg B
Rear

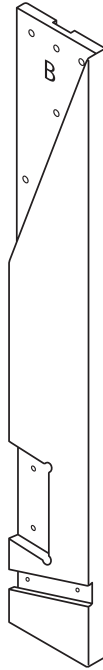

Leg B
Front

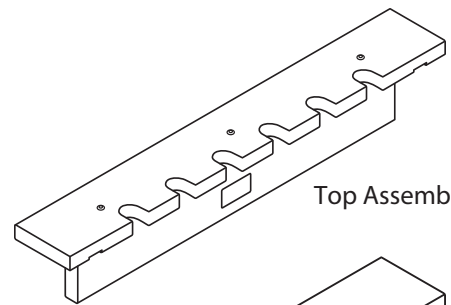

Top Assembly

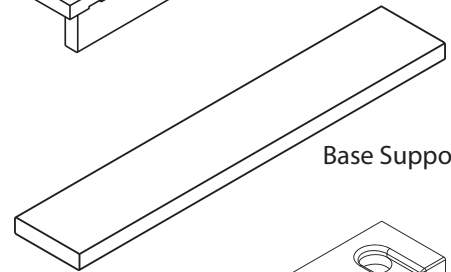

Base Support

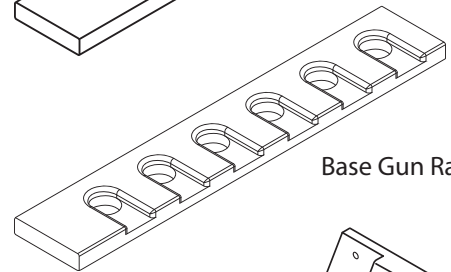

Base Gun Rail

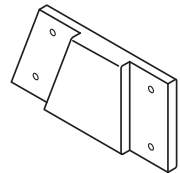

Support

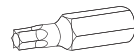

T20 Torx Bit x 1



1" Cap Screw x 14

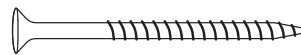

2.5" Exterior Wood Screw x 12

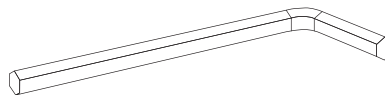

5/32" Allen Wrench x 1

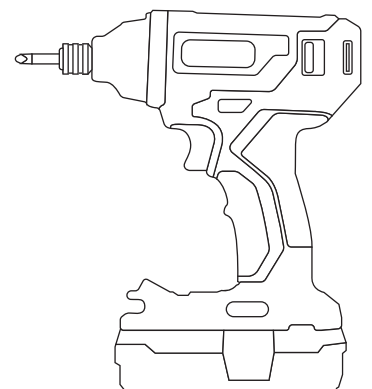

Drill (not included)

Fully Assembled

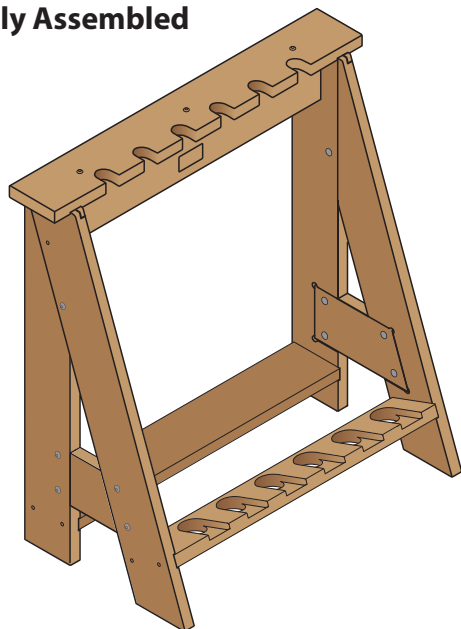

ASSEMBLY

STEP 1

Using allen wrench to fasten screws:

1. Assemble leg A front to leg A back using three 1" cap screws.
2. Attached support to legs using four 1" cap screws.
3. Repeat #1 & 2 using B legs, support and 1" cap screws.

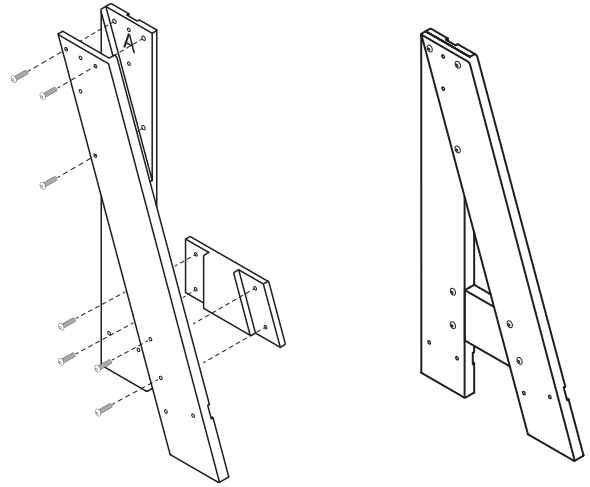

STEP 2

Using drill and T25 Torx bit:

1. Slide top assembly into grooves on leg assemblies.
2. Attach using four 2.5" wood screws.
Do not over tighten wood screws. They can easily strip out.

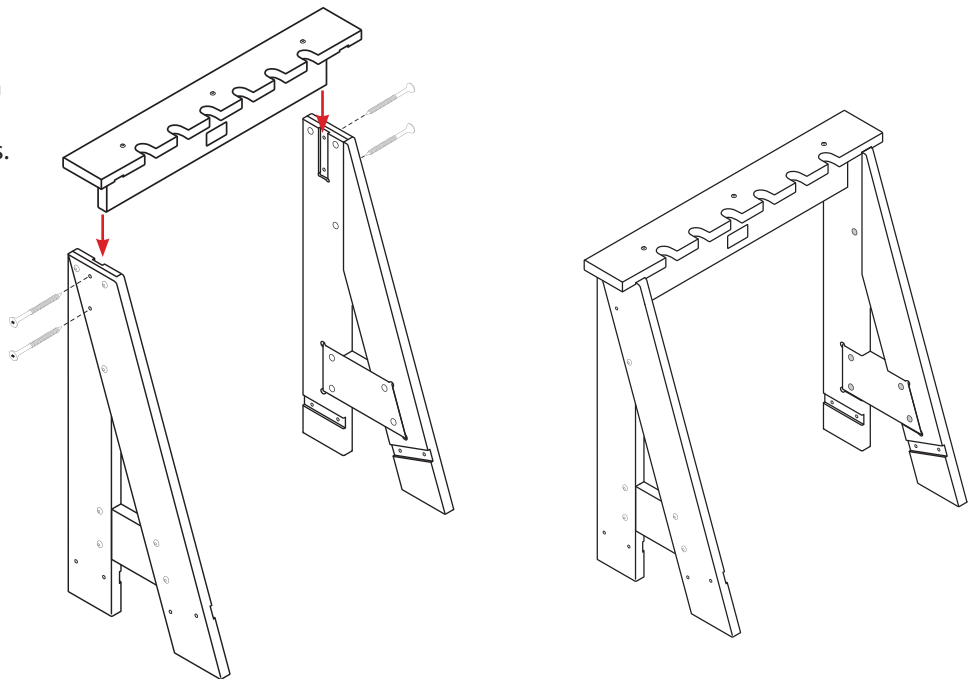

STEP 3

Using drill and T25 Torx bit:

1. Slide base rails into grooves on leg assemblies.
2. Attach using four 2.5" wood screws.
Align flush with legs. **Do not over tighten wood screws. They can easily strip out.**
3. Repeat for other side of rack.

